



Product specifications

One-touch control with:

## BATTERY OR WIRED SWITCHES

SWITCH-B-GM, SWITCH-B-SM, SWITCH-W-GM  
Mesh network enabled battery powered or 24V wire-powered switches with gang-mount or surface mount case



### PRODUCT OVERVIEW

The Amatis Controls Switch is a one-touch control interface designed specifically to work with our 6LoWireless lighting control system.

Each individually programmable Switch can control entire lighting zones or individual fixtures, giving users instant control of their lighting systems.

Users can easily turn lights on and off, press-and-hold for responsive dimming or create custom commands for preset lighting scenes, enabling personal control.

### CONFIGURATIONS

The Amatis Switch is available in three configurations:

- Low-voltage option that can be mounted in a gang box
- Battery-powered option that can be mounted in a gang box or a battery-powered option that can be surface mounted.

### FEATURES

SWITCH FUNCTIONALITY	Two-button switch for ON/OFF Control
	Push and hold functionality for dimming
	Configurable for personal control
	Available with 24V power input
EASY, PLUG-AND-PLAY INSTALLATION	Fits standard Decora® wall plate or mounts to any surface with included adhesive
	On-board indicator LED
SIMPLE, WIRELESS COMMISSIONING	Remotely configurable / upgradeable
	Amatis app easily commissions all devices on the mesh network
	Unique IPv6 address
CODE COMPLIANCE	Complies with ASHRAE 90.1-2016 and CA Title 24 requirements
WARRANTY	10-year limited warranty with uninterrupted connection of the Amatis Border Router device from a network

1-gang mount

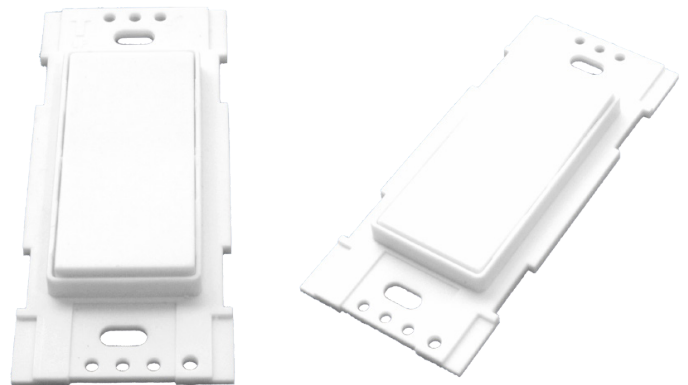

Surface mount



## TECHNICAL SPECIFICATIONS

		SWITCH-B-SM	SWITCH-B-GM	SWITCH-W-GM
COMMUNICATION	Wireless transmit range	Up to 75 feet to nearest mesh connected device		
	Communication protocol	Embedded 6LoWireless		
	Encryption	AES 128-bit		
ELECTRICAL	Batteries included	2x CR2450 3V coin cell batteries (included)		
	Batteries required	Yes		No
	Battery life	5+ years or 250,000 clicks		N/A
MECHANICAL	Dimensions	2 5/8" (67mm) w 1 1/4" (32mm) h 1/2" (12.7mm) d	4 1/8" (105mm) w 1 3/4" (44mm) h 1/2" (12.7mm) d	4 1/8" (105mm) w 1 3/4" (44mm) h 1/2" (12.7mm) d
	Color	White		
	Finish	Matte		
	Trigger actions	Long/short press/release		
	Mounting	Adhesive surface mount	Gang box	
ENVIRONMENTAL	Installation environment	Commercial, Indoor/Covered		
	Temperature range	4°F to 140°F (-20°C to 60°C)		
GENERAL	Standards / Ratings	FCC, ETL (pending) Device contributes to Amatis system compliance with ASHRAE 90.1-2016 and CA Title 24 requirements		

## LED INDICATOR REFERENCE TABLE

LED response	LED illuminates when pressed
Reference direction	LED situated at "ON" side of switch

### Dimensioned isometrics

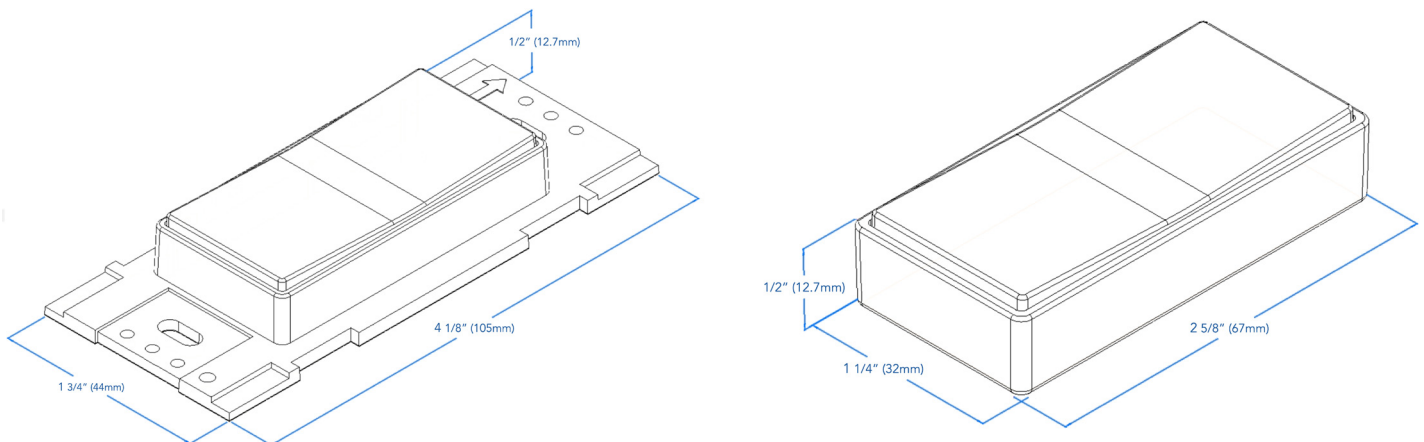

Note: Actual performance may vary as a result of end-user environment and application. Specifications subject to change without notice.